

features

- True RMS Measurement
- LED Step Indication
- Automatic / Manual Step Operation
- Automatic or Manual C.T. Polarity
- Automatic C/K Detection or User Preset
- Automatic or User Preset Switching Sequence (rotational for same size grouping)
- Operation from 1% Load
- Viewable Parameters:
V, I, Cos Φ , PF, Hz, W, Var, THD-V, THD-I, Harmonics Spectrum up to 15th order for V & I (secondary values for I, W, Var)
- Individual Capacitor Step Info:
- Hour run (accumulative)
- Usage count (accumulative)
- Secondary 1-phase Var value (present)

- Programmable Over Voltage & THD-V alarm
- Alarm Information:
- Under / Over Compensate
- Under / Over Voltage
- Overload, THD-V Limit High
- User selectable capacitor protection for Over voltage & THD-V
- Selectable contact for Signal Alarm Output or Exhaust Fan Output
- External Plug-in Module for: A-01s / A-01sp (RS-485 Modbus RTU) isolated type
- Software Lock to prevent unauthorized modification of parameters
- Complies with:
IEC 61000-6-2 / 6-4 Standards
IEC 60255-27-Clause 10.6.4.2 / 4.3

Panel Overview

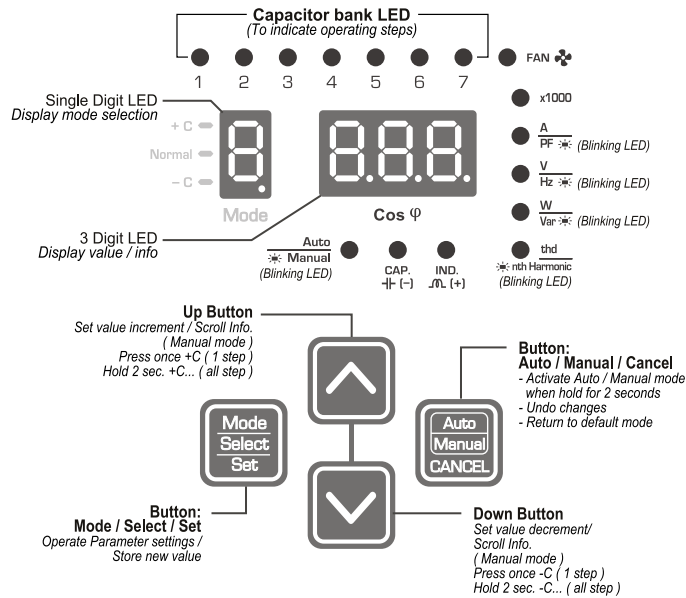

Technical Data

Aux Power Supply	AC range	: 85 ~ 275 VAC, 45~65 Hz
	Consumption	: <3 VA
Power Measurement	Accuracy (W, Var, Cos Φ , PF)	: $\pm 1.0\%$
AC Current Measurement	Range	: 0.01 ~ 6.50 A
	Accuracy	: $\pm 1.0\%$
	CT range	: ./5A
	Burden	: < 0.1 VA at 5A
AC Voltage Measurement	Range	: Same as Aux supply
	Accuracy	: $\pm 1.0\%$
Frequency Measurement	Range	: 45 ~ 65 Hz
	Accuracy	: $\pm 0.1\%$
LEDs Indication	Individual Steps, Fan, x1000, A / PF, V / Hz, W / Var, thd / nth Harmonic, Ind., Cap., Auto / Manual	
Mechanical	Output Relay (Individual Steps / Alarm / Fan) Rating	: SPST 7A, 250 VAC
	Electrical Life	: 100,000 operations at rated current
	Mechanical Life	: 5 x 10 ⁶ operations
	No voltage release	: < 40ms
	Display	: 7-Segment LED (3 + 1 digit)
	Operating Temp.	: -5°C ~ +55°C
	Humidity	: 56 days at 93%RH, 40°C non-condensing
	IP Rating	: IP54 (front panel)
	Installation	: Panel flush mount
	Weight	: 280 g

Casing

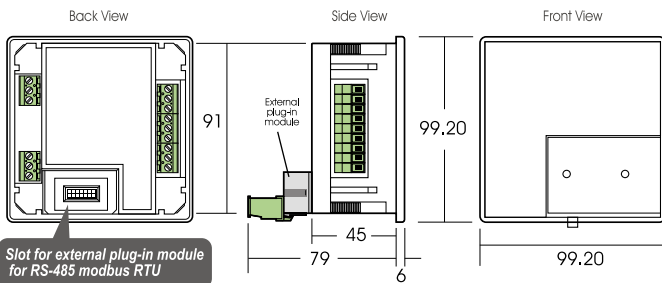

Panel Cut-out :
92 x 92

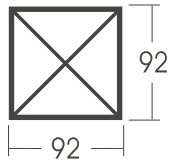

Note: All measurement in mm.



Note: Specification subject to change without prior notification (please visit www.delab.com.my for latest specification)

Auto / Manual Operation Mode

When NO mode is selected (mode display is blank), the default display will be Cos Φ of the network. User can activate Auto or Manual mode here.

In Auto mode, the unit will automatically operate the steps based on load condition and setting of parameters. In Manual mode, user will need to operate the steps by pressing [Up] or [Down].
*If Keypad Lock is ON in Special Setting Mode [L], manual mode cannot be activated.

To activate Auto / Manual mode:



Press and hold the 'Auto / Manual' button for 2 seconds to switch between Auto or Manual mode.
Press [Cancel] button once to stop continuous manual step in/out,



Press [Up] button once to step in (+C)
Hold for 2 seconds to continuous step in (+C...C)
Press [Down] button once to step out (-C)
Hold for 2 seconds to continuous step out (-C...C)

Manually selecting which cap bank to step in or out:

In Manual mode, user can select any available cap bank to step in or out by following steps below:

- Enter Manual mode by pressing 'Auto/Manual' button for 2 seconds.
- Press [Select] button until mode [3].
- Press [Up] and [Down] simultaneously and hold for 3 seconds.
- Select the desired cap bank to step in using [Up] or [Down] button.
- Press [Select] once to step in or out.

To exit, press [Cancel] button twice.

Wiring

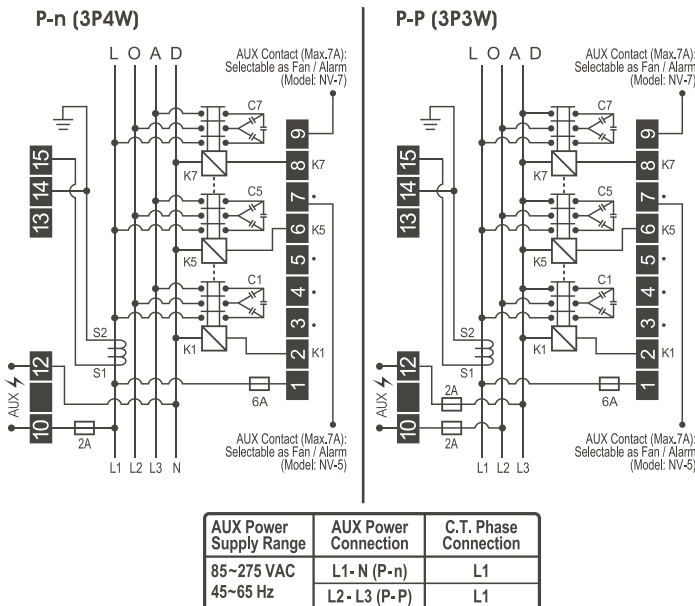



Setting Mode : 1 to 8

Mode 1: C/K Setting - Press [Select] until mode [1] (Refer to the Calculation of C/K diagram)
Set correct C/K value using [Up] or [Down] button. Newly selected C/K value will flash. Press [Set] to confirm new value or press [Cancel] to undo changes while modifying. The default setting for this mode is 'Aut' which means automatic C/K detection. It is recommend to manually set the C/K value if the load is fast-varying.

Mode 2: Target Cosφ Setting - Press [Select] until mode [2]

To modify, press [Up] or [Down] then press [Set] to confirm. To undo, press [Cancel] button. It is recommend not to set target value to <0.90 ind.

Mode 3: No. of Steps for Connection - Press [Select] until mode [3]

Set correctly the number of available capacitor bank that would be utilized in the network using [Up] or [Down]. Press [Set] to confirm the setting. To undo, press [Cancel] button.

Mode 4: Switching Program Sequence Selection - Press [Select] until mode [4]

User can select one of the 8 pre-set sequence 'P-0' to 'P-7' or choose 'Aut' in order to let unit detects the ratio of individual cap banks. Press [Up] or [Down] to modify the switching program. Press [Set] to confirm the new selection. To undo, press [Cancel] button.

To view selected pre-set description (Refer to Program Sequence diagram)

Press [Up] and [Down] simultaneously and hold for 1 sec. Scrolling description will be displayed.

To view automatic switching program description (Refer to Ratio Description Range)

When 'Aut' is selected, press [Up] and [Down] simultaneously and hold for 1 sec, ratio of current capacitor step will be displayed and starting from step 2. Press [Up] to view the following step's ratio of capacitor and press [Down] to view previous step's ratio of capacitor.

Mode 5: Switching Interval Setting - Press [Select] until mode [5]

'On' will be displayed momentarily, user can modify the appropriate switching interval for cap banks to step in. Press [Up] or [Down] to change the interval time and [Set] to confirm.

Press [Select] again, 'tOff' will be displayed shortly. User can modify the appropriate switching interval for cap banks to step out. Press [Up] or [Down] to change the interval time and [Set] to confirm. To undo, press [Cancel] button. (Switching interval allows load condition to settle such that frequent switching can be avoided.)

Mode 6: Re-connection Inhibit Setting - Press [Select] until mode [6]

It is recommend to set time delay here to prevent steps which have just step out from connecting again immediately as the capacitor bank needs time to fully discharge in order to prolong the life of the capacitor bank. Press [Up] or [Down] to change the re-connection inhibit interval and [Set] to confirm. To undo, press [Cancel] button.

Mode 7: Voltage > Setting - Press [Select] until mode [7]

This setting is meant for over-voltage alarm. The default setting is 'OFF' which means that over-voltage is not monitored. Press [Up] or [Down] to adjust the desired value for over-voltage monitoring and press [Set] to confirm the setting. To undo, press [Cancel] button.

Alarm 7 (Single digit LED) will flash and alarm output contact will be energized to indicate over-voltage condition. Over-voltage alarm will automatically clears when voltage drops below set limit.

Over-voltage protection for capacitor : If special mode 'Pt' is set to 'ALL' or 'OV', all steps will turn off one at a time until no more steps are connected when over-voltage alarm is active. The unit resumes normal operation if voltage drops below set limit.

Mode 8: thd-V > setting - Press [Select] until mode [8]

This setting is meant for high thd-V alarm. The default setting is '5.0' which means that thd-V is monitoring at 5.0% of thd-V. User may set it to 'OFF' to stop monitoring thd-V. Press [Up] or [Down] to adjust the desired value for thd-V monitoring and press [Set] to confirm the setting. To undo, press [Cancel] button.

Alarm 8 (Single digit LED) will flash & alarm output contact will be energized to indicate high thd-V (%) condition. High thd-V alarm will automatically clears when thd-V (%) drops below set limit.

Thd-V protection for capacitor : If special mode 'Pt' is set to 'ALL' or 'thd', all steps will turn off one at a time until no more steps are connected when high thd-V alarm is active. The unit resumes normal operation if thd-V (%) drops below set limit.



Info Viewing : Mode A to F

Mode A: Alarm Display

Press and hold [Select] for 1 second in any mode [1] to [8] to enter mode [A]

Display will show "..." if there is no alarm detected by unit. (Refer to Alarm Definition)

To exit, press [Cancel] button.

Mode B: View Parameters : Press [Select] in mode [A] to enter this mode

The first display will be I-sec (A) and 'A/PF' LED is lit. Press [Down] to move to Power Factor (PF) display and during power factor display, LED 'A/PF' will flash. Press [Down] again to move to Voltage display and during voltage display, LED 'V/Hz' will lit. Press [Down] again to move to Frequency display and during frequency display, LED 'V/Hz' will flash. Press [Down] again to move to Active Power (P) display and during active power display, LED 'W/Var' will lit. Press [Down] again to move to Reactive Power (Q) display and during reactive power display, LED 'W/Var' will flash. Press [Down] again, it will move back to I-sec (A) display again. It will rotate as I-sec > PF > V > Hz > W > Var > I-sec > PF and so on if press [Down]. However, it will rotate as I-sec > Var > W > Hz > V > PF > I-sec > Var and so on if press [Up]. To exit, press [Cancel] button.

Mode C: View Cap Banks Utilisation Hours - Press [Select] after mode [b]

The first display will be 1st step of cap bank's utilisation hours. Press [Up] to view for next step's utilisation hours. Press [Down] to view for previous step's utilisation hours. All of the utilisation hour's display have to x1000.

Reset the selected step's utilisation hours : Press and hold [Cancel] for 3 seconds at selected step to reset the selected step's utilisation hours after the user replaced new cap bank in order to monitoring new utilisation hours for the new cap bank. To exit, press [Cancel] button once.

Mode C: View Cap Banks Switching Count - Press [Select] after mode [c1]

The first display will be 1st step of cap bank's switching count. Press [Up] to view for next step's switching count. Press [Down] to view for previous step's switching count.

Reset the selected step's switching count : Press and hold [Cancel] for 3 seconds at selected step to reset the selected step's switching count after the user replaced new contactor in order to monitoring new switching count for the contactor. To exit, press [Cancel] button once.

Mode C: View Cap Bank 1-phase Secondary Var - Press [Select] after mode [c2]

The first display will be 1st step of cap bank's 1-phase Secondary Var. Press [Up] to view for next step's 1-phase secondary Var. Press [Down] to view for previous step's 1-phase secondary Var. To exit, press [Cancel] button.

Mode C: View thd-V (%) and h1~h15 harmonic spectrum (V) -

Press [Select] after mode [c3]

The default display will be thd-V in %. In order to view the harmonic spectrum (V), press [Up] to search for the nth harmonic voltage spectrum. To exit, press [Cancel] button.

Mode C: View thd-I (%) and h1~h15 harmonic spectrum (A) -

Press [Select] after mode [d1]

The default display will be thd-I in %. In order to view the harmonic spectrum (A), press [Up] to search for the nth harmonic ampere spectrum. To exit, press [Cancel] button.

Mode C: View firmware version - Press [Select] after mode [d2]

This mode is for user to view firmware version of this unit only. To exit, press [Cancel] button.

Mode C: View total operation hour -

Press [Select] until mode [F oPh] is being displayed.

This modes show the total time of the unit that has been in operation. Display will show a value (x1000 hr). To exit, press [Cancel] button.

e.g. $0.05 \times 1000 = 50$ hours



Special Setting Modes

When NO mode is selected (mode display is blank),

- Press [Select] and [Cancel] button simultaneously and hold for 5 seconds.
- Press [Up] or [Down] button to modify
- Press [Set] button to confirm and proceed to next mode

Mode G: Software keypad lock : OFF or ON

Mode H: Relay Output Function

FAn: Fan control output will energized if any cap bank is running.
ALr: Alarm contact output will energized if alarm triggered.

Mode I: Fan Duty Option

StP: Fan control output will energized once cap bank is running & de-energized if there is no cap bank is running.
Aut: Fan control output will energized once cap bank is running. After 30 minutes, fan control output will de-energized for 5 minutes and energized again after 5 minutes in order to prevent the fan runs continuously.

Mode J: Protection for Cap Bank

OFF: No protection
OV: When voltage (V) is greater than the set limit, all steps will turn off one at a time.
thd: When thd-V (%) is greater than the set limit, all steps will turn off one at a time.
ALL: When either voltage (V) or thd-V (%) is greater than the set limit, all steps will turn off one at a time.

Mode K: C.T. Polarity Setting

Aut: Automatic C.T. Polarity Detection
Frd: C.T. Polarity is in Forward direction
reV: C.T. Polarity is in Reverse direction

Mode L: Frequency Setting

Aut: Operation of unit based on network frequency. The allowance network frequency is 45 ~ 65 Hz.
50: Frequency fixed at 50 Hz
60: Frequency fixed at 60 Hz

Mode M: Network Selection

P-N: Phase to Neutral Power Connection
P-P: Phase to Phase Power Connection

Mode N: Static Duty Cycle Interval

This options allows the device to alternate the capacitors in commission. It functions by switching on one extra capacitor step in the same grouping such that the network will achieve the target Cosφ & then allowing the device to switch off the capacitor step which has been in commission for the longest period in the same capacitor grouping. User may set the interval as 10, 15, 20, 30, 60, 90 and 120 minutes or OFF if not desirable. This option functions only if there are available steps in the same grouping. Priority is given to capacitor steps with higher grouping.

Mode O: RS485 Plug-in module selection

A01: A-01s / A-01sp
non: None

Mode P: Modbus Address

Selectable from 1 ~ 247

Mode Q: Baud Rate Setting

Set the baud rate for Modbus communication between host computer and unit. Selectable as:
(3 = 300, 6 = 600, 12 = 1200, 24 = 2400, 48 = 4800, 96 = 9600, 192 = 192000 or 288 = 288000) bps

Mode R: Parity Setting

Set the parity for Modbus communication between host computer and unit. Selectable as:
non: None
Odd: Odd
Evn: Even

Mode S: End Setting Press [Select] to exit and save setting or [Cancel] to go back.

Setting Range

C/K Value	: Auto or 0.01 ~ 0.80 (step of 0.01)
Targer Cos φ	: 0.85 (Ind.) ~ 0.90 (Cap.) (step of 0.01)
Switching Program	: Auto or P-0 ~ P-7
Switching Interval	: (t-on) : 1s ~ 250s (step of 1s) (t-off) : 1s ~ 250s (step of 1s)
Reconnection Inhibit	: OFF or 5s ~ 900s (step of 5s)
V> (Over Voltage)	: OFF or 100 V ~ 260 V (step of 1 V)
thd-V > (%)	: OFF or 3, 4, 5, 6, 7, 8, 10%

Calculation of C/K

It is recommended to set C/K to a slightly lower than calculated value, so in the above example, set C/K value to 0.13 (approx. 80% of calculated)

E.g.:
1st cap bank = 25KVAR (true kvar)
(CT) ratio = 800/5 = 160

C/K value = KVAR (1st cap) ÷ CT ratio
= 25 ÷ 160
= 0.15

Actual kvar versus rated kvar of Capacitor

The rated kvar of capacitor is true only if the rated voltage is supplied. In case when rated supply is very much different from the voltage supply, follow the example below to calculate the true kvar.

$$\text{True kvar} = \frac{(\text{actual voltage})^2}{(\text{rated voltage})^2} \times \text{rated kvar}$$

e.g. 30 kvar rated 525 V
actual voltage supply = 415 V

$$\text{Then true kvar} = \frac{415^2}{525^2} \times 30 = 19 \text{ kvar}$$

Program Sequence

Auto	Automatic decision by device
P-0	Linear
P-1	1 : 1 : 1 : 1 : 1
P-2	1 : 2 : 2 : 2 : 2
P-3	1 : 2 : 4 : 4 : 4
P-4	1 : 1 : 2 : 2 : 2
P-5	1 : 1 : 2 : 2 : 4
P-6	1 : 1 : 1 : 2 : 2
P-7	1 : 2 : 4 : 8 : 8

Ratio Description Range

1.0	1.5	2.0	2.5	3.0	4.0	5.0	6.0	8.0	10.0
e.g.:									
Steps	1	2	3	4					
kvar	5	10	15	15					
ratio	1.0	2.0	3.0	3.0					
(fixed)									

Alarm Definition

OC	: Over-Compensated
UC	: Under-Compensated
UV	: Under-Voltage
OV	: Over-Voltage
OL	: Overload
FrrE	: Frequency Out-of-range
thd	: thd-V Limit High